

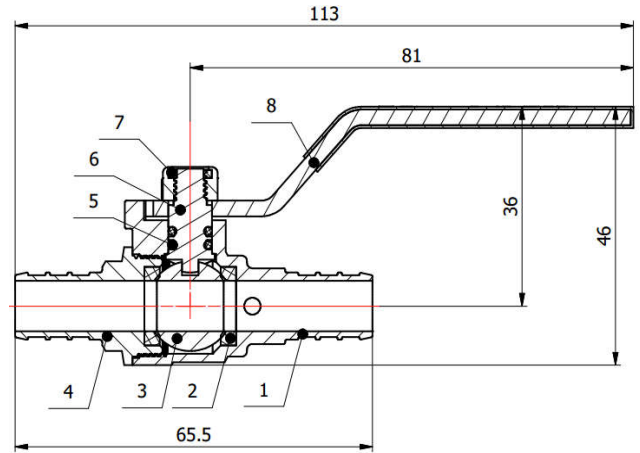

BRASS BALL VALVE

2 Piece-Full Port-Pex X Pex Connections-200 WOG



Features

- .Double O-Ring Stem
- .Teflon seal, Chrome plated no lead ball
- .100% leak tested
- .Dezincification resistant brass alloy
- .Wanted surfaces contain less than 0.25% lead content

Approvals:



CUPC list (3/8" - 1")

NSF List (3/8" - 1")

AB1953 List (3/8" - 1")

Material Specifications

No	Part	Materials
1	Body	Brass-C46500
2	Ball	Brass-C46500
3	Sealings	Teflon
4	Pex End	Brass-C46500
5	Oring	EPDM
6	Stem	Brass-C46500
7	Nut	A3
8	Handle	A3
9	Rubber	EPDM
10	Drain Nut	Brass-C46500

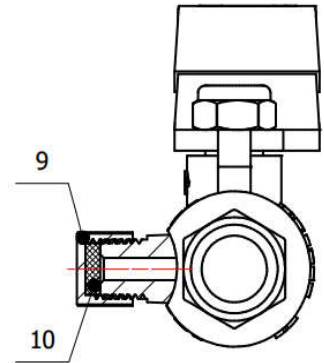

The ball valves did not leak during 82°C water temperature and 0.86 Kpa for 30 minutes.

The Ball Valve were subject to a life cycle test for 5,000 cycles

No leakage applying a hydrostatic pressure of 300 psi at 23°C, maintain the pressure for 5 min with the valve closed.

Pex Tubing complied with the dimensional requirements ASTM F1807 or CSA B137.5

Ball Valves and parts intended for the delivery of potable water complied with applicable requirements of NSF/ANSI 61.