

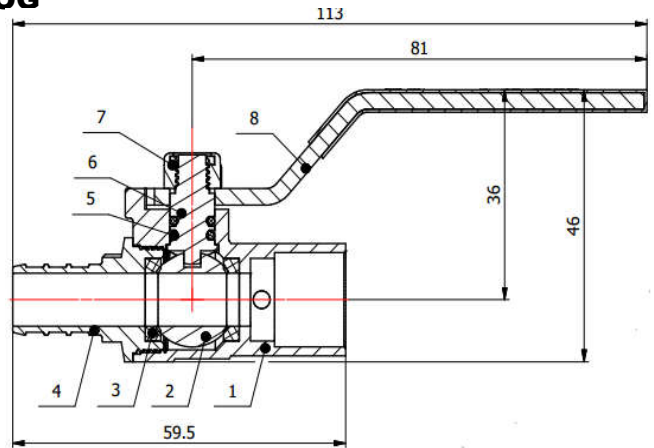

BRASS BALL VALVE

2 Piece-Full Port-Solder X Pex Connections-200 WOG



Features

- .Double O-Ring Stem
- .Teflon seal,Chrome plated no lead ball
- .100% leak tested
- .Dezincification resistant brass alloy
- .Wanted surfaces contain less than 0.25% lead content

Approvals:



CUPC list (1/2" - 1")

NSF List (1/2" - 1")

AB1953 List (1/2" - 1")

Material Specifications

No	Part	Materials
1	Body	Brass-C46500
2	Ball	Brass-C46500
3	Sealings	Teflon
4	Pex End	Brass-C46500
5	Oring	EPDM
6	Stem	Brass-C46500
7	Nut	A3
8	Handle	A3
9	Rubber	EPDM
10	Drain Nut	Brass-C46500

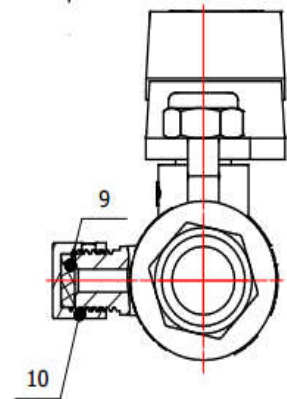

The ball valves did not leak during 82°C water temperature and 0.86 Kpa for 30 minutes.

The Ball Valve were subject to a life cycle test for 5,000 cycles

No leakage applying a hydrostatic pressure of 300 psi at 23°C, maintain the pressure for 5 min with the valve closed.

Ends for soldering to copper tubes or fittings complied with the dimensional requirements of ASME B16.18 or ASME B 16.22.

Pex Tubing complied with the dimensional requirements ASTM F1807 or CSA B137.5

Ball Valves and parts intended for the delivery of potable water complied with applicable requirements of NSF/ANSI 61.