

# Thermostatic Mixing Valve

## Installation Manual

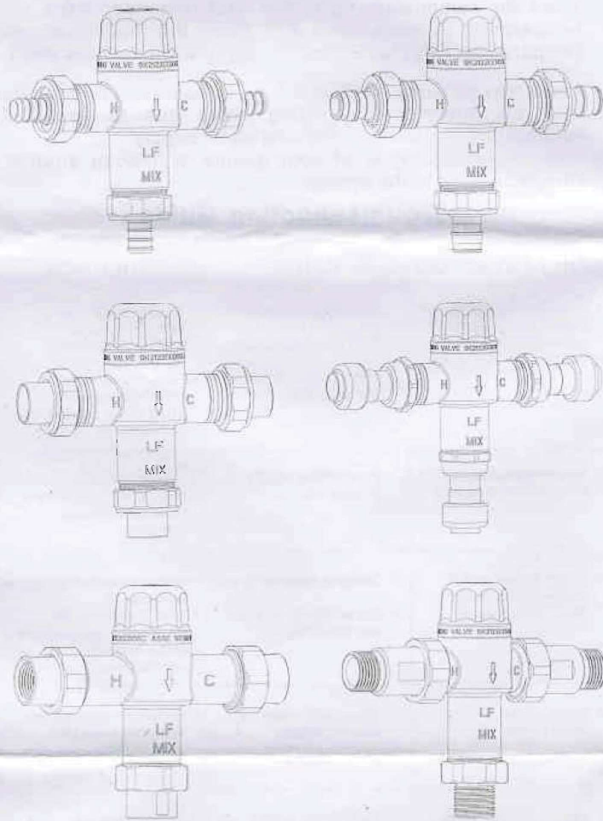

ASSE 1017 & 1070 Approved



### VALVE SPECIFICATIONS

Outlet temperature range: 80~120°F(27~49°C)  
 Temperature, hot supply: 180°F max(82°C)  
 Temperature, cold supply: 40~80°F(4~27°C)  
 Temperature stability (nominal): ±5°F(±2.8°C)-See Note 1.  
 Temperature differential: [1/2"]±10°F(11°C)-See Note 2.  
 (between hot supply and outlet Temperature) [3/4"]±10°F(11°C)-See Note 2.

Hydrostatic pressure: 150 psi max  
 Permitted supply pressure variation: ±20%-See Note 3.  
 Flow rate @ 45psi pressure loss: [1/2"]9gpm  
 [3/4"]11gpm  
 Flow rate, minimum: 0.5gpm  
 Flow rate, maximum: [1/2"]10gpm @ 60psi pressure loss  
 [3/4"]12gpm @ 60psi pressure loss

#### Notes:

- As tested in accordance with ASSE 1070.
- This is the minimum difference required between the valve outlet temperature and the hot supply temperature to ensure shut-off of outlet flow in the event of cold supply failure, in accordance with ASSE 1070.
- Maximum permitted variation in either supply pressure in order to control the outlet temperature to within ±5°F. Excessive changes in supply pressure may cause changes in outlet temperature, that exceeds ±5°F.

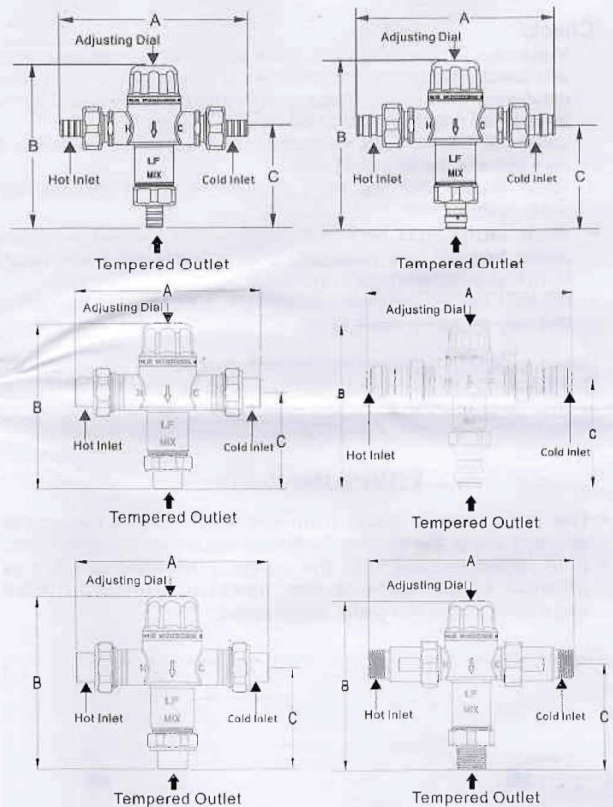

DIMENSIONS	A	B	C
1/2" (1807 PEX)	5.3" (135mm)	4.6" (117mm)	2.8" (72mm)
3/4" (1807 PEX)	5.2" (131mm)	4.6" (116mm)	2.8" (70mm)
1/2" (1960 PEX)	5.5" (139mm)	4.7" (119mm)	2.9" (74mm)
3/4" (1960 PEX)	5.8" (148mm)	4.9" (124mm)	3" (78mm)
1/2" (Solder)	4.9" (124mm)	4.4" (112mm)	2.7" (68mm)
3/4" (Solder)	5.7" (146mm)	4.7" (119mm)	2.3" (73mm)
1/2" (Pushfit)	6.7" (170mm)	5.3" (134mm)	3.5" (90mm)
3/4" (Pushfit)	7" (178mm)	5.5" (139mm)	3.7" (93mm)
1/2" (F NPT)	5.4" (136mm)	4.4" (113mm)	2.7" (68mm)
3/4" (F NPT)	6" (153mm)	4.8" (122mm)	3" (76mm)
1/2" (M NPT)	5.8" (148mm)	4.8" (123mm)	3" (77mm)
3/4" (M NPT)	5.8" (148mm)	4.8" (123mm)	3" (77mm)

Diagram 1 - Valve Dimensions

### IMPORTANT

Failure to comply with all aspects of these instructions may result in unsafe performance. All installations must comply with relevant state and local authority requirements.

#### Flush the system thoroughly before fitting the valve:

It is CRITICAL that all debris is flushed from the pipework prior to installing the valve. Not flushing the system properly is the most common cause of system difficulties.

#### Commission the valve:

Every valve is factory-set to a nominal temperature of 120°F. Every valve must be adjusted on-site to ensure correct delivery of the desired mixed water temperature, as installation conditions can vary from site to site.

## CHECKING / SERVICING THE VALVE

### Check:

- Measure and note all site parameters (pressure, temperature, etc.) and check against the specifications of the chosen valve. If the site conditions are outside those specified for the valve then they must be rectified prior to installing the valve.
- Valve **MUST NOT** be subjected to heat during installation as this may damage the valve internals.
- Valve **MUST NOT** be fitted on steam-supplied systems, but to water systems only.
- Valve **MUST NOT** be frozen. If the valve is installed in a situation where freezing is a possibility, then suitable insulation must be fitted to prevent damage to the valve.
- **DO NOT** use excess thread sealant (in liquid, tape or other forms) as this may cause the valve to fail.

Leave a copy of these instructions with the client for future reference. **Recommend to the client that the valve be checked annually to ensure its continued function.**

- We recommend that the valve is checked at least once per year to ensure its continued function. For installations with poor or unknown water quality, or other adverse supply conditions, it may be necessary to check the valve at more frequent intervals.
- The temperature should be checked at the same outlet as used for commissioning in the first instance. If the temperature is more than 5°F from the commissioning temperature, refer to Troubleshooting guide on the table sheet below.
- There may be some variations in the temperature of the water from the thermostatic mixing valve due to seasonal temperature variations in the cold water supply.
- If the water supply is of poor quality, a filter or strainer should be fitted to the system.

### Troubleshooting Guide

FAULT / SYMPTOM	CAUSE	SOLUTION
1. The desired mixed water temperature cannot be obtained or valve is difficult to set.	<ul style="list-style-type: none"> <li>• Inlet temperatures are not within specific limits.</li> <li>• Hot and cold supplies are reversed.</li> </ul>	<ul style="list-style-type: none"> <li>• Ensure inlet temperatures are within the specified limits for the valve.</li> <li>• Refit the valve with Hot/Cold supplies fitted to the correct connections.</li> </ul>
2. Mixed temperature unstable or changing over time.	<ul style="list-style-type: none"> <li>• Fluctuating supply pressures.</li> </ul>	<ul style="list-style-type: none"> <li>• Install pressure regulating valves on both hot and cold supplies.</li> </ul>
3. Either full hot or full cold water flowing from outlet fixture.	<ul style="list-style-type: none"> <li>• Valve is incorrectly set.</li> <li>• Hot and cold supplies are reversed.</li> </ul>	<ul style="list-style-type: none"> <li>• Adjust mixed temperature as required.</li> <li>• Refit the valve with Hot/Cold supplies fitted to the correct connections.</li> </ul>
4. No flow from the valve outlet.	<ul style="list-style-type: none"> <li>• Hot or cold water supply failure.</li> <li>• Filter is blocked.</li> </ul>	<ul style="list-style-type: none"> <li>• Restore inlet supplies and check mixed temperature.</li> <li>• Clean filter.</li> </ul>
5. Flow rate reduced or fluctuating.	<ul style="list-style-type: none"> <li>• Fluctuating supply pressures.</li> <li>• Filter is blocked.</li> </ul>	<ul style="list-style-type: none"> <li>• Install pressure regulating valves.</li> <li>• Clean filter.</li> </ul>
6. Mixed water temperature does not change when temperature adjuster is altered.	<ul style="list-style-type: none"> <li>• Hot and cold supplies are reversed.</li> </ul>	<ul style="list-style-type: none"> <li>• Refit the valve with Hot/Cold supplies fitted to the correct connections.</li> </ul>
7. Valve is noisy.	<ul style="list-style-type: none"> <li>• Excessive water velocity.</li> <li>• Valve sized incorrectly.</li> </ul>	<ul style="list-style-type: none"> <li>• Reduce water velocity (best achieved by fitting a pressure regulating valve).</li> <li>• Check valve specifications and ensure the appropriate valve is used for required flow.</li> </ul>

### Fitting the Valve

- The mixed water outlet from the valve should be used to supply outlets used primarily for personal hygiene purposes.
- It is recommended that the valve is installed as close as possible to the point of use; however, it may be fitted anywhere on the hot water supply pipe.

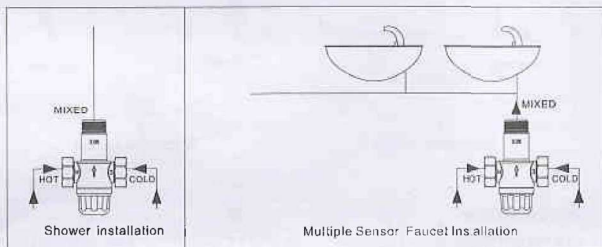

Diagram 2 – Typical Installations

### TEMPERATURE ADJUSTMENT

- Prior to setting the valve it is necessary for the hot water source to be switched on and delivering hot water at the designated temperature.
- Test the mixed water temperature at the nearest outlet being supplied by the valve. This should be opened to allow a flow rate of 1 to 1.5 gpm (4 to 6 L/min).
- A thermometer must be used at the nearest outlet to the valve to ensure the correct mixed water temperature is achieved.
- Allow the water to run for at least one minute to ensure the mixed water temperature has settled.
- To adjust the mixed outlet temperature of the valve, remove the cap to gain access to the adjusting spindle. The spindle should be rotated - clockwise to reduce the temperature, counter-clockwise to increase the temperature-until the desired set point is reached. (Refer to diagram 3).
- Once the set temperature is achieved, the cap should be snapped onto the valve to cover the spindle.

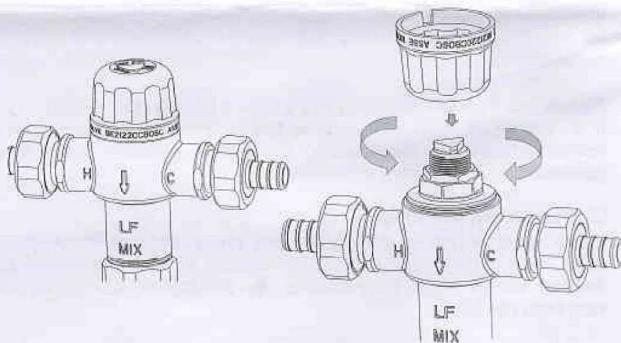

Diagram 3 – Valve Adjustment

### Notes:

---



---



---



---



---



---



---



---



---



---

Installer, please provide the following information and leave these instructions with the client:

Installed By: \_\_\_\_\_  
 Date: \_\_\_\_\_  
 Pressure At the Valve: \_\_\_\_\_ PSI  
 Mix Temperature: \_\_\_\_\_ °F